

LEGEND	SYMBOL	NO.	LATIN	COMMON NAME	SIZE	HEIGHT	SPREAD	INSTALLATION
CANOPY								
	TR	6	TILIA REDMOND	LINDEN	25'-50'	15'-20'	2 1/2" CALIPER-SINGLE STEM FORM ONLY	
	GB	3	GINKGO BILOBA	GINKGO NOTE: ONLY MALE	25'-50'	15'-20'	2 1/2" CALIPER-SINGLE STEM FORM ONLY	
	SM	4	TILIA REDMOND	SUGAR MAPLE	25'-50'	30'-50'	2 1/2" CALIPER-SINGLE STEM FORM ONLY	
SHRUBS								
	EGA	10	TILIA OCCIDENTALIS EMERALD GREEN	EMERALD GREEN ARBORVITAE	7'-12'	4'-5'	3 GAL	
	RD	43	CORNUS BAILEYI	REDTIG DOGWOOD	3'-0'	3'-4'	3 GAL	
	SV	31	SPIRAEA X VANHOUTTEI	VANHOUTTEI SPIRAEA	3'-4'	3'-4'	3 GAL	
	KR	21	ROSA	KNOCK OUT ROSE	3'-4'	2'-3'	3 GAL	
PERENNIALS								
	FRG	22	CALAMAGOSTIS KARL FORESTER	FEATHER RED GRASS - KARL FORESTER	2'-4'	2'-3'	3 GAL	
	NR	24	NEPETA RACEMOSA	CATMINT WALKER'S LOW	10" - 12"	2'-3'	1 GAL	
GROUND COVER								
	LM	18	LAMIUM MACULATUM	SPOTTED DEADNETTLE	1'-0"	2'-3'	1 GAL	

LANDSCAPE NOTE:
EXISTING PARKWAY AND ON-SITE INTERIOR TREES ARE TO BE PROTECTED WHILE PROJECT IS UNDER CONSTRUCTION AND WILL BE REPLACED BY CURRENT AND SUBSEQUENT OWNER IF DAMAGED.

THE UNDERSIGNED ACKNOWLEDGES THAT THE LANDSCAPE PLANTING SHOWN ON THE ATTACHED LANDSCAPE PLAN(S) FOR THE PROPERTY AT 155 W. LAURENCE AVE, CHICAGO IL 60640, TO THE BEST OF THE UNDERSIGNED APPLICANT'S KNOWLEDGE, BEEN DESIGNED AND WILL BE INSTALLED, MAINTAINED, AND REPLACED, AS REQUIRED, BY CURRENT AND SUBSEQUENT OWNERS IN ACCORDANCE WITH THE REQUIREMENTS OF TITLE 10, CHAPTER 32 OF THE CHICAGO MUNICIPAL CODE, THE LANDSCAPING STANDARDS OF THE CHICAGO ZONING ORDINANCE, AND THE 'GUIDE TO THE CHICAGO LANDSCAPE ORDINANCE'.

SIGNED: *Antonio Fanizza* DATE: 02/25/2022
PRINT NAME: SHER ELI

LANDSCAPE NOTE:
THE UNDERSIGNED LANDSCAPE ARCHITECT, REGISTERED IN THE STATE OF ILLINOIS, ACKNOWLEDGES THAT THE LANDSCAPE PLANTING PLAN AND CONSTRUCTION DETAILS SHOWN ON THE ATTACHED LANDSCAPE PLAN(S) FOR THE PROPERTY AT 155 W. LAURENCE AVE, CHICAGO ILLINOIS 60640, HAS BEEN DESIGNED IN ACCORDANCE WITH THE REQUIREMENTS OF TITLE 10, CHAPTER 32 OF THE CHICAGO MUNICIPAL CODE, THE LANDSCAPING STANDARDS OF THE CHICAGO ZONING ORDINANCE, AND THE 'GUIDE TO THE CHICAGO LANDSCAPE ORDINANCE'.

SIGNED: *Antonio Fanizza* DATE: 02/25/2022
PRINT NAME: ANTONIO FANIZZA

NOTE: ESTIMATED TIME OF PLANTING JUNE 15, 2022 OR DEC 15, 2022

PARKING LOT AND VEHICULAR USE AREA CALCULATION

VEHICULAR USE AREA	9531 SQFT
INTERNAL LANDSCAPED AREA REQUIRED	9531 X 15% = 1166 SQFT
INTERNAL LANDSCAPED AREA PROVIDED	835 SQFT
INTERNAL TREE REQUIRED	1 TREE FOR 125 SQFT = 6 TREES

- GENERAL NOTES:**
- SOD TO BE KENTUCKY BLUEGRASS BLEND
 - ALL TREES AND SHRUBS SHALL BE MULCHED WITH A MINIMUM OF FOUR (4) INCH DEPTH SHREDDED BARK WOOD CHIPS OR OTHER ALL ORGANIC MATERIAL. ALL FLOWER AND GROUND COVER BEDS SHALL BE MULCHED WITH A MINIMUM TWO (2) INCH DEPTH SHREDDED BARK OR OTHER ALL ORGANIC MATERIAL.
 - NO LANDSCAPING MATERIAL SHALL BE LOCATED CLOSER THAN TEN (10) FEET TO FIRE HYDRANTS OR OTHER ABOVE GROUND UTILITIES.
 - PRUNE TREES AFTER INSTALLATION PER DIRECTION OF LANDSCAPE ARCHITECT
 - REPLACE FOLIAGE BY MIN. 25%. REMOVE WHOLE BRANCHES NOT TIPS. REMOVE DOUBLE LEADERS, NARROW V CROTCHES, RUBBING BRANCHES AND REMOVE DEAD DAMAGED, OR BROKEN BRANCHES.
 - TREES MAY REQUIRE STAKING OF GUYING AFTER PLANTING

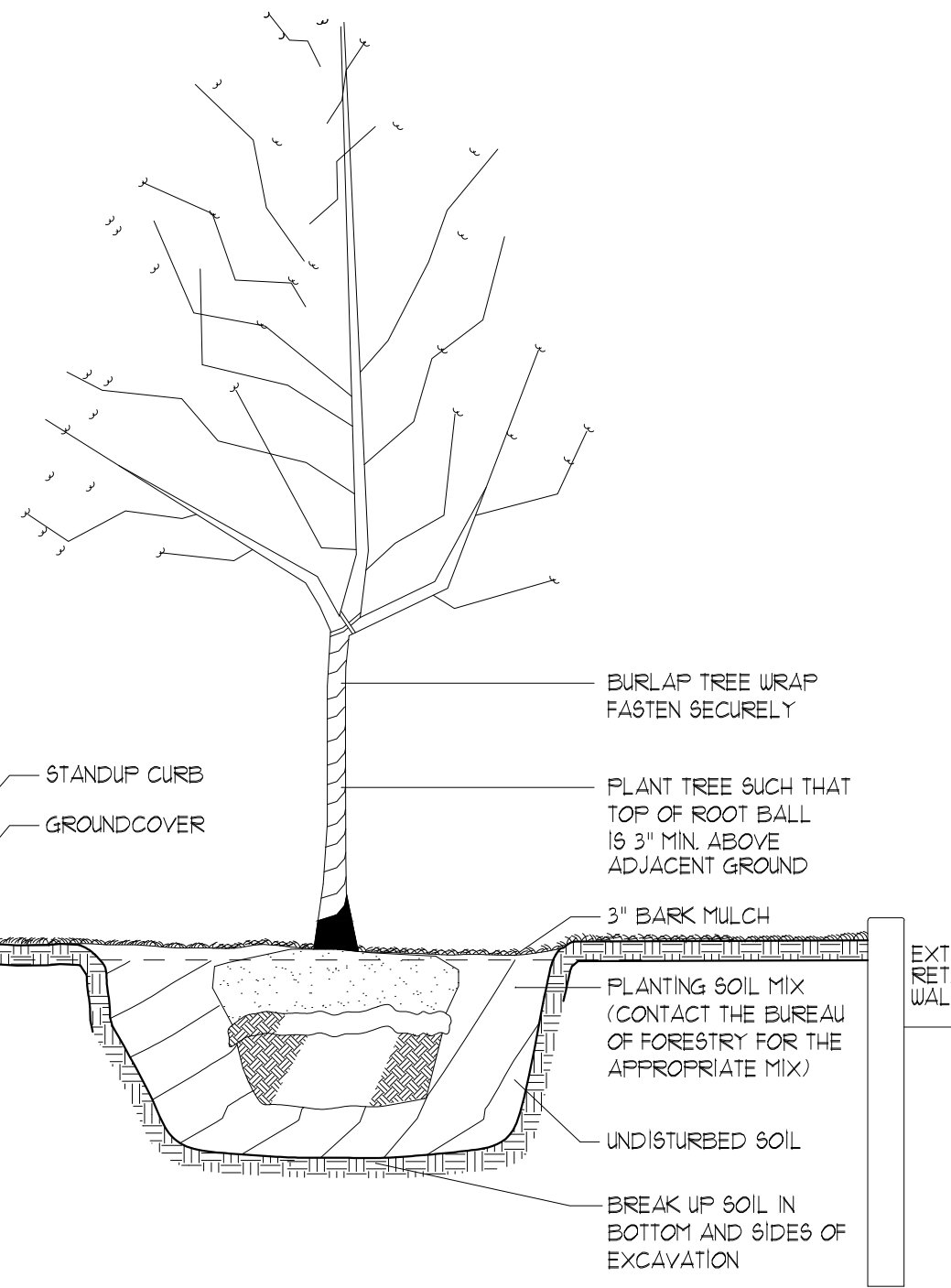

TREE PLANTING SECT./DET
SCALE: NOT TO SCALE

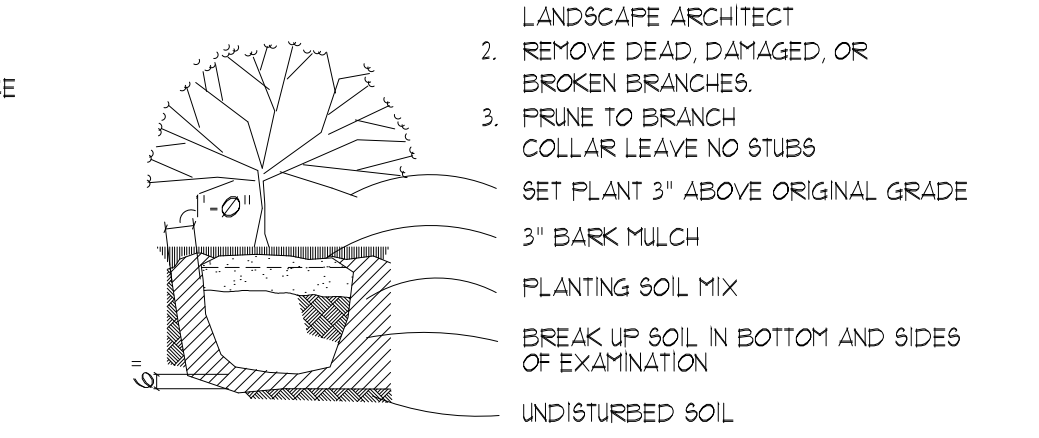

SHRUBS PLANTING SECT./DET
SCALE: NOT TO SCALE

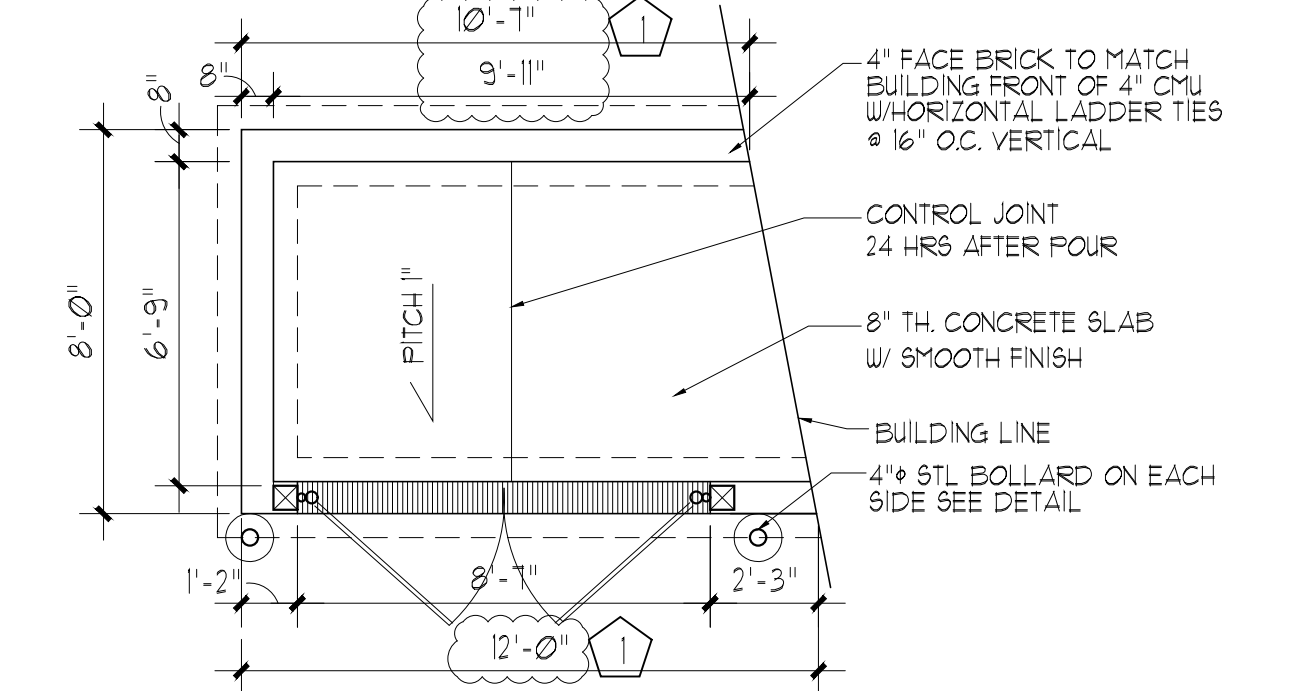

DUMPSTER ENCLOSURE PLAN

SCALE: 1/4" = 1'-0"

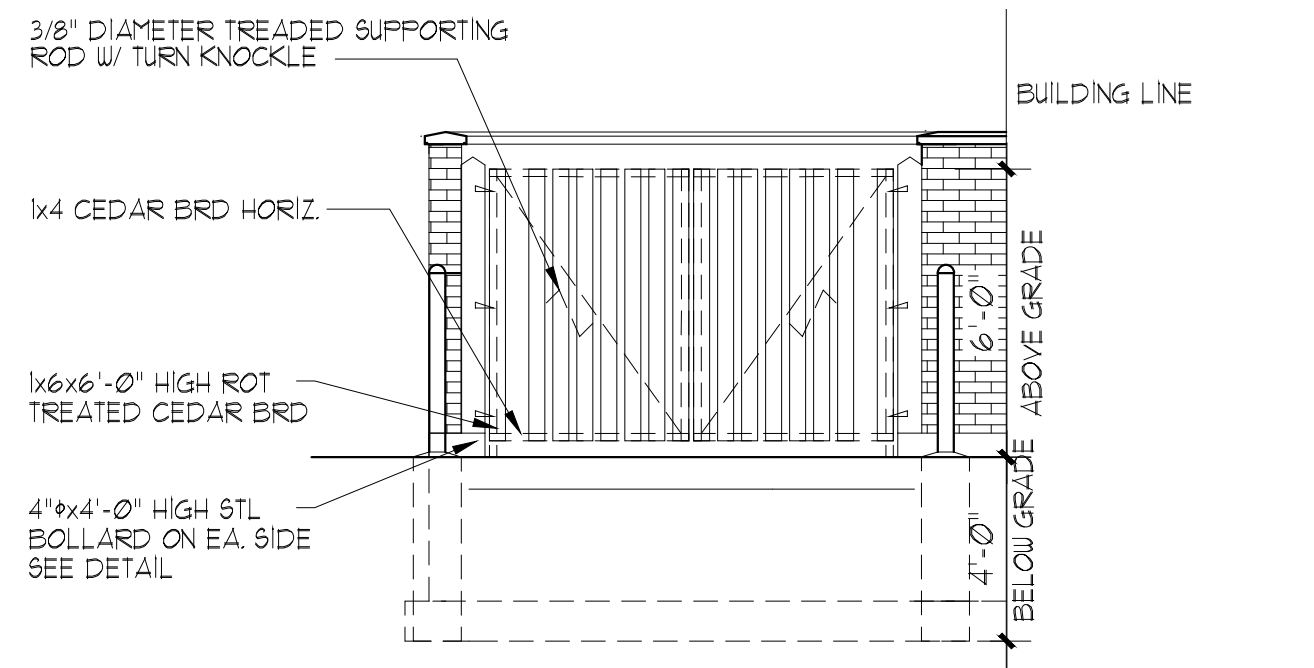

DUMPSTER ENCLOSURE ELEVATION

SCALE: 1/4" = 1'-0"

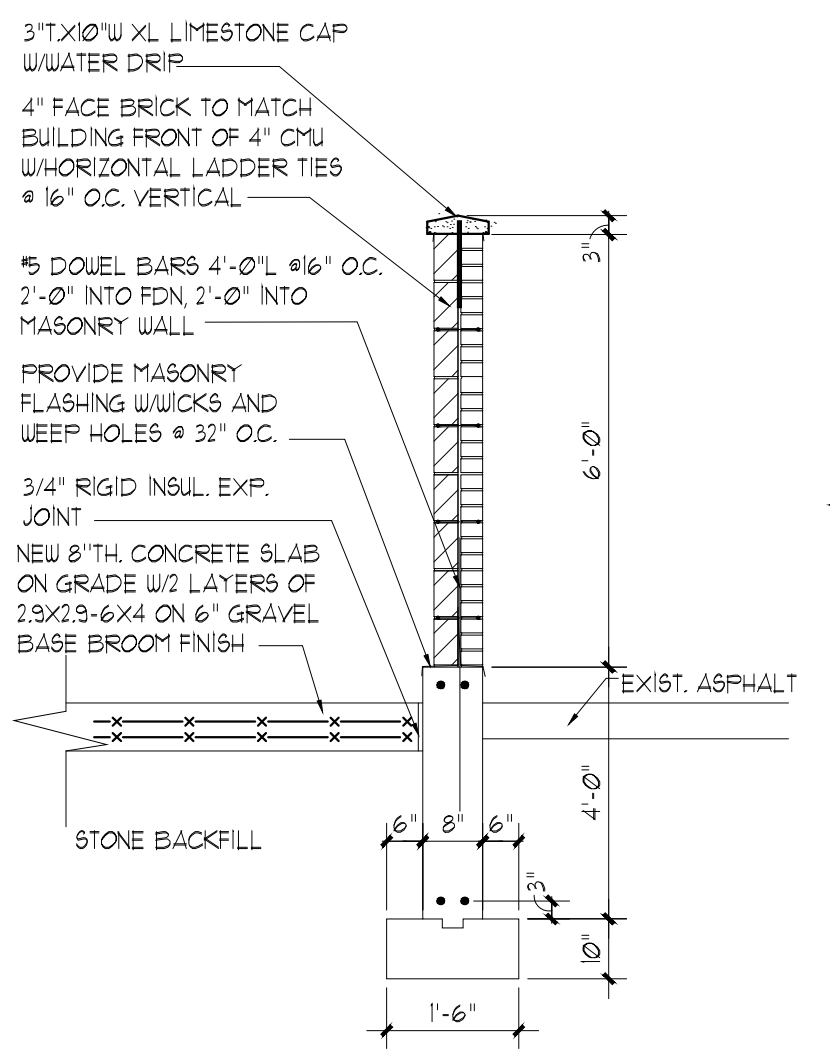

SECTION

SCALE: 3/8" = 1'-0"

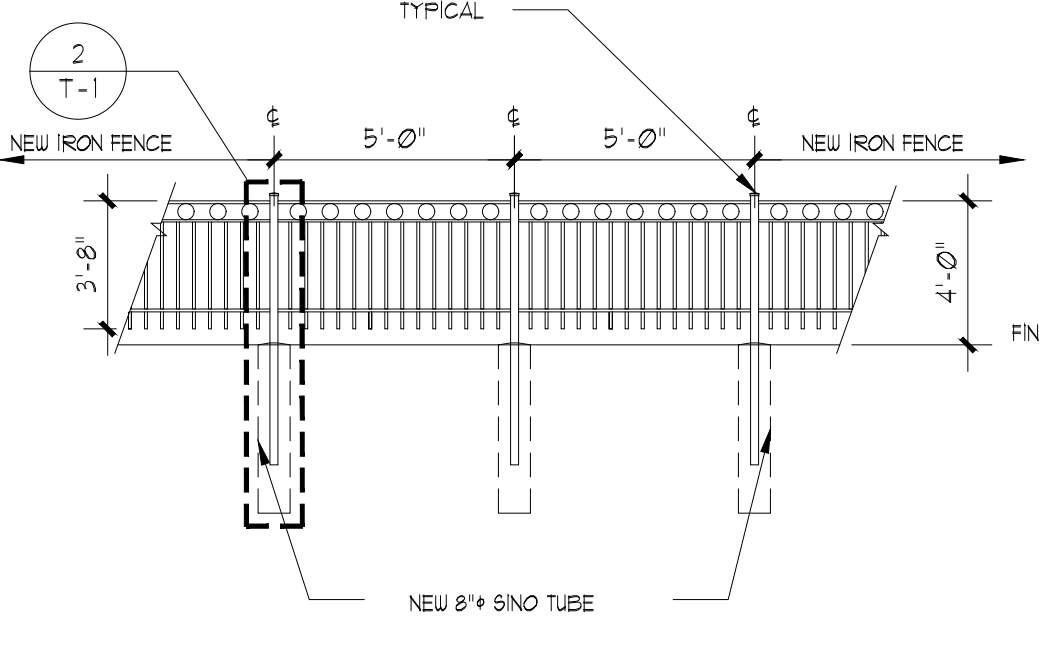

NEW IRON FENCE

SCALE: 1/4" = 1'-0"

- NOTE:**
- RECOMMENDED GRATE SIZES: 6"x6", 5"x5", 6" DIA, 5" DIA. (SEE PLAN) AS LARGE AS POSSIBLE TO MAXIMIZE PLANTING SOIL VOLUME.
 - ROOT BALL OF TREE MUST FIT THROUGH THIS OPENING.
 - DRAINAGE SYSTEM MAY BE NEEDED UNDER CERTAIN SOIL CONDITIONS.

- GENERAL NOTES:**
- SEED TO BE KENTUCKY BLUEGRASS BLEND
 - ALL TREES AND SHRUBS SHALL BE MULCHED WITH A MINIMUM OF FOUR (4) INCH DEPTH SHREDDED BARK WOOD CHIPS OR OTHER ALL ORGANIC MATERIAL. ALL FLOWERS AND GROUND COVER BEDS SHALL BE MULCHED WITH A MINIMUM TWO (2) INCH DEPTH SHREDDED BARK OR OTHER ALL ORGANIC MATERIAL.
 - NO LANDSCAPING MATERIAL SHALL BE LOCATED CLOSER THAN TEN (10) FEET TO FIRE HYDRANTS OR OTHER ABOVE GROUND UTILITIES.

- GENERAL NOTES:**
- PRUNE TREES AFTER INSTALLATION PER DIRECTION OF LANDSCAPE ARCHITECT
 - REPLACE FOLIAGE BY MIN. 25%. REMOVE WHOLE BRANCHES NOT TIPS. REMOVE DOUBLE LEADERS, NARROW V CROTCHES, RUBBING BRANCHES AND REMOVE DEAD DAMAGED, OR BROKEN BRANCHES.
 - PRUNE AT BRANCH COLLARS. LEAVE NO STUBS
 - TREES MAY REQUIRE STAKING OF GUYING AFTER PLANTING

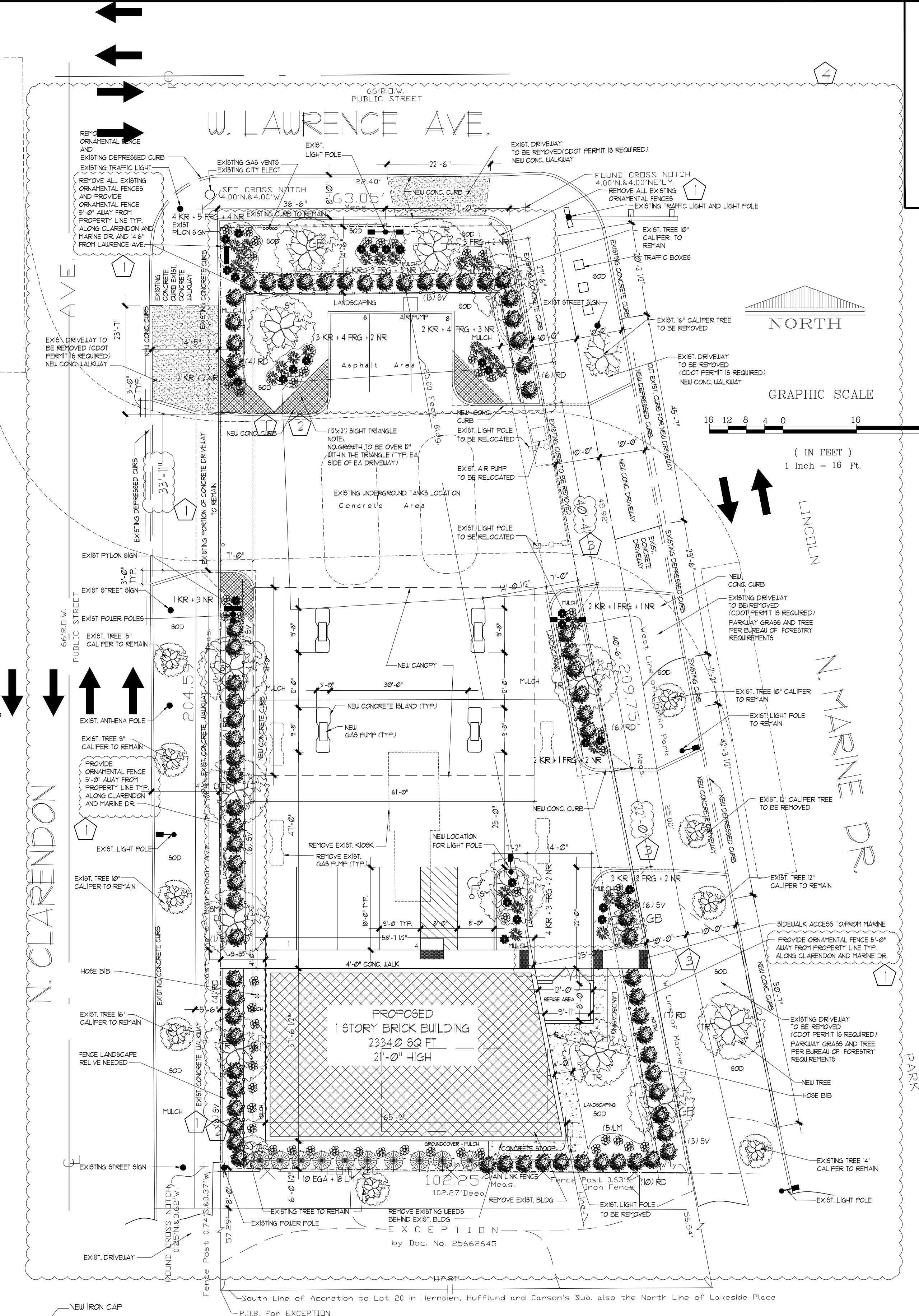

PROPOSED LANDSCAPING PLAN

SCALE: 1" = 15'-0"

BY CURRENT AND SUBSEQUENT OWNERS IN ACCORDANCE WITH THE REQUIREMENTS OF TITLE 10, CHAPTER 32 OF THE CHICAGO MUNICIPAL CODE, THE LANDSCAPING STANDARDS OF THE CHICAGO ZONING ORDINANCE, AND THE 'GUIDE TO THE CHICAGO LANDSCAPE ORDINANCE'.

ANTONIO FANIZZA LTD
ARCHITECTS
2363 LEICHER LANE
DEER PLAIN, ILLINOIS 60016
TEL: (847) 633-5664 FAX: (847) 823-1664
Email: antonio.fanizza@cmca.net

© 2023 ANTONIO FANIZZA ASSOC. LTD. THESE DRAWINGS AND SPECIFICATIONS ARE PROPERTY OF ANTONIO FANIZZA ASSOC. LTD. THESE DRAWINGS ARE PREPARED FOR USE ON THIS SPECIFIC SITE AND FOR A SPECIFIC DATE AND SHALL NOT BE COPIED, OR REPRODUCED IN ANY FORM OR BY ANY MEANS, WITHOUT WRITTEN AUTHORIZATION. UNAUTHORIZED USE IS NOT ALLOWED. IT IS FURTHER ASSUMED PRIOR TO DRAWINGS USE, ALL FEES HAVE BEEN PAID IN FULL. FAILURE TO DO SO, THE USER WILL BE RESPONSIBLE FOR ALL COURT COSTS AND LEGAL FEES.

HEREBY CERTIFY THAT THIS PLAN AND SPECIFICATION WAS PREPARED BY ME OR UNDER MY DIRECT SUPERVISION AND THAT I AM A FULLY REGISTERED ARCHITECT UNDER THE LAWS OF THE STATE OF ILLINOIS AND THE CITY OF CHICAGO CODES AND ORDINANCES. THEY ARE IN COMPLIANCE WITH ALL APPLICABLE CODES INCLUDING THE ENVIRONMENTAL BARRIERS ACT (416-100) AND THE ILLINOIS ACCESSIBILITY CODE (111.400) CODE CODE 4001 AS SIGNED BY MY HAND AND SEAL.

NO.	REVISION
1	PER CITY COMMENTS 10/05/2021
2	PER CITY COMMENTS 11/02/2021
3	PER CITY COMMENTS 01/15/2022
4	PER CITY COMMENTS 02/22/2023

CERTIFICATION AND SEAL
FEBRUARY 22, 2023
DATE

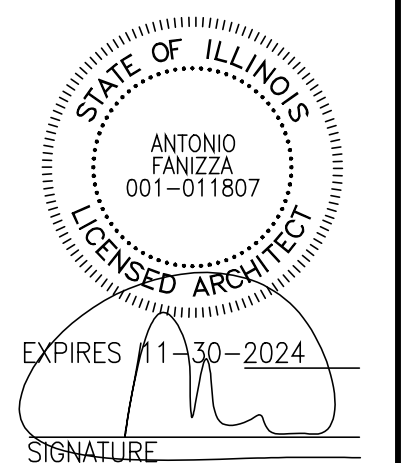

EXPIRES 11-30-2024

SIGNATURE

DRAWING NAME: **LANDSCAPING PLAN**
PROJECT NAME: **BP GAS STATION**
155 W. LAURENCE AVENUE, CHICAGO ILLINOIS

released to const
job no. 2154
scale AS SHOWN
date 12.06.2021
drawn by AB/ID
checked by AF

sheet
L-1.0